

q-rook monoid algebras, Hecke algebras, and Schur-Weyl duality

Tom Halverson*

Department of Mathematics and Computer Science
Macalester College
St. Paul, MN 55105
halverson@macalester.edu

and

Arun Ram**

Department of Mathematics
University of Wisconsin, Madison
Madison, WI 53706
ram@math.wisc.edu

In memory of Sergei Kerov 1946-2000

When we were at the beginnings of our careers Sergei's support helped us to believe in our work. He generously encouraged us to publish our results on Brauer and Birman-Murakami-Wenzl algebras, results which had in part, or possibly in total, been obtained earlier by Sergei himself. He remains a great inspiration for us, both mathematically and in our memory of his kindness, modesty, generosity, and encouragement to the younger generation.

0. Introduction

The rook monoid R_k is the monoid of $k \times k$ matrices with entries from $\{0, 1\}$ and at most one nonzero entry in each row and column. Recently, the representation theory of its “Iwahori-Hecke” algebra $R_k(q)$, called the q -rook monoid algebra, has been analyzed. In particular, a Schur-Weyl type duality on tensor space was found for the q -rook monoid algebra and its irreducible representations were given explicit combinatorial constructions. In this paper we show that, in fact, the q -rook monoid algebra is a quotient of the affine Hecke algebra of type A. With this knowledge in hand, we show that the recent results on the q -rook monoid algebras actually come from known results about the affine Hecke algebra. In particular

- (a) The recent combinatorial construction of the irreducible representations of $R_k(q)$ by Halverson [Ha] turns out to be a special case of the construction of irreducible calibrated representations of affine Hecke algebras of Cherednik [Ch] (see also Ram [Ra]), the construction of irreducible representations of cyclotomic Hecke algebras by Ariki and Koike

* Research supported in part by National Science Foundation grant DMS-0100975.

** Research supported in part by National Science Foundation grant DMS-9971099, the National Security Agency and EPSRC grant GR K99015.

[AK], and the construction of the irreducible representations of Iwahori-Hecke algebras of type B by Hoefsmit [Ho].

- (b) The Schur-Weyl duality for the q -rook monoid algebra discovered by Solomon [So2-4] and studied by Halverson [Ha] turns out to be a special case of the Schur-Weyl duality for cyclotomic Hecke algebras given by Sakamoto and Shoji [SS].

Though these results show that the representation theory of the q -rook monoid algebra is “just” a piece of the representation theory of the affine Hecke algebra, this was not at all obvious at the outset. It was only on the analysis of the recent results in [So4] and [Ha] that the similarity to affine Hecke algebra theory was noticed. This observation then led us to search for and establish a concrete connection between these algebras.

The q -rook monoid algebra was first studied in its $q = 1$ version in the 1950’s by Munn [Mu1-2]. Solomon [So1] discovered the general q -version of the algebra as a Hecke algebra (double coset algebra) for the finite algebraic monoid $M_n(\mathbb{F}_q)$ of $n \times n$ matrices over a finite field with q elements, with respect to the “Borel subgroup” B of invertible upper triangular matrices. Later Solomon [So2] found a Schur-Weyl duality for $R_k(1)$ in which $R_k(1)$ acts as the centralizer algebra for the action of the general linear group $GL_n(\mathbb{C})$ on $V^{\otimes k}$ where $V = L(\varepsilon_1) \oplus L(0)$ is the direct sum of the “fundamental” n -dimensional representation and the trivial module $L(0)$ for $GL_n(\mathbb{C})$. Then Solomon [So3,4] gave a presentation of $R_k(q)$ by generators and relations and defined an action of $R_k(q)$ on tensor space.

Halverson [Ha] found a new presentation of $R_k(q)$ and used it to show that Solomon’s action of $R_k(q)$ on tensor space extends the Schur-Weyl duality so that $R_k(q)$ is the centralizer of the quantum general linear group $U_q\mathfrak{gl}(n)$ on $V^{\otimes k}$ where now $V = L(\varepsilon_1) \oplus L(0)$ is the direct sum of the “fundamental” and the trivial module for $U_q\mathfrak{gl}(n)$. Halverson also exploited his new presentation to construct, combinatorially, all the irreducible representations of $R_k(q)$ when $R_k(q)$ is semisimple.

The main results of this paper are the following:

- (a) We find yet another presentation (1.6) of $R_k(q)$ by generators and relations.
- (b) Our new presentation shows that

$$R_k(q) = H_k(0, 1; q)/I,$$

where $H_k(0, 1; q)$ is the Iwahori-Hecke algebra of type B_k with parameters specialized to 0 and 1, and I is the ideal generated by the minimal ideal of $H_2(0, 1; q)$ corresponding to the pair of partitions $\lambda = ((1^2), \emptyset)$.

- (c) We show that the irreducible representations of $R_k(q)$ found in [Ha] come from the constructions of irreducible representations of $H_k(0, 1; q)$.
- (d) We use the fact that $R_k(q)$ is a quotient of $H_k(0, 1; q)$ and the fact that the Iwahori-Hecke algebra $H_k(q)$ of type A_{k-1} is a quotient of $R_k(q)$ to easily determine, in Corollary 2.21, the values of q for which $R_k(q)$ is semisimple. These values were first found in [So4] using other methods.
- (e) We show that the Schur-Weyl duality between $R_k(q)$ and $U_q\mathfrak{gl}(n)$ comes from the Schur-Weyl duality of Sakamoto and Shoji [SS] for the cyclotomic Hecke algebras (Theorem 3.5).
- (f) We give a *different* Schur-Weyl duality for algebras $A_k(u_1, u_2; q) = H_k(u_1, u_2; q)/I$, where $u_1, u_2 \neq 0$, $H_k(u_1, u_2; q)$ is the Iwahori-Hecke algebra of type B_k and I is the ideal generated by the minimal ideal of $H_2(u_1, u_2; q)$ corresponding to the pair of partitions $\lambda = ((1^2), \emptyset)$. This Schur-Weyl duality comes from the Schur-Weyl duality of Orellana and Ram for the affine Hecke algebra (Theorem 3.3).

Acknowledgements. A. Ram thanks the Isaac Newton Institute for the Mathematical Sciences at Cambridge University for support for a very pleasant residency during which the research in this paper was completed.

1. Presentations of the q -rook monoid algebras

Fix $q \in \mathbb{C}^*$. The q -rook monoid algebra is the algebra $R_k(q)$ given by generators

$$P_1, P_2, \dots, P_k \quad \text{and} \quad T_1, T_2, \dots, T_{k-1}$$

with relations

$$\begin{aligned} \text{(A1)} \quad T_i^2 &= (q - q^{-1})T_i + 1, & 1 \leq i \leq k-1, \\ \text{(A2)} \quad T_i T_{i+1} T_i &= T_{i+1} T_i T_{i+1}, & 1 \leq i \leq k-2, \\ \text{(A3)} \quad T_i T_j &= T_j T_i, & |i-j| > 1, \\ \text{(R1)} \quad P_i^2 &= P_i, & 1 \leq i \leq k, \\ \text{(R2)} \quad P_i P_j &= P_j P_i, & 1 \leq i, j \leq k, \\ \text{(R3)} \quad P_i T_j &= T_j P_i, & 1 \leq i < j \leq k, \\ \text{(R4)} \quad P_i T_j &= T_j P_i = q P_i, & 1 \leq j < i \leq k, \\ \text{(R5)} \quad P_{i+1} &= q P_i T_i^{-1} P_i = q(P_i T_i P_i - (q - q^{-1})P_i), & 1 \leq i \leq k-1. \end{aligned} \tag{1.1}$$

The algebra $R_k(q)$ was introduced by Solomon [Sol] as an analogue of the Iwahori-Hecke algebra for the finite algebraic monoid $M_k(\mathbb{F}_q)$ of $k \times k$ matrices over a finite field with q elements with respect to its ‘‘Borel subgroup’’ of invertible upper triangular matrices. The presentation of $R_k(q)$ given above is due to Halverson [Ha].

When $q = 1$, $R_k(q)$ specializes to the algebra of the rook monoid R_k that consists of $k \times k$ matrices with entries from $\{0, 1\}$ and *at most* one nonzero entry in each row and column. These correspond with the possible placements of nonattacking rooks on an $k \times k$ chessboard. In this specialization, T_i becomes the matrix obtained by switching rows i and $i+1$ in the identity matrix I and, for $1 \leq i \leq k-1$, P_i becomes the matrix $E_{i+1, i+1} + E_{i+1, i+2} + \dots + E_{k, k}$, where $E_{i, j}$ is the matrix with a 1 in position (i, j) and zeros elsewhere. The generator P_k specializes to the 0 matrix (which is not the 0 element in the monoid algebra).

Remark 1.2. The definition of $R_k(q)$ in [Sol, 3, 4] and [Ha] uses generators \tilde{T}_i in place of T_i . These generators satisfy $\tilde{T}_i^2 = (q-1)\tilde{T}_i + q$ in place of (A1). In our presentation, if we let $\tilde{T}_i = qT_i$, then $\tilde{T}_i^2 = q^2((q - q^{-1})T_i + 1) = (q^2 - 1)qT_i + q^2 = (q^2 - 1)\tilde{T}_i + q^2$, which shows that our algebra is the same except with parameter q^2 instead of q .

Define

$$X_i = T_{i-1} T_{i-2} \cdots T_1 (1 - P_1) T_1 T_2 \cdots T_{i-1}, \quad 1 \leq i \leq k, \tag{1.3}$$

so that $X_{i+1} = T_i X_i T_i$.

Lemma 1.4. *In $R_k(q)$ we have the following relations*

- (a) $P_i P_j = P_j P_i = P_j$, for $i \leq j$.
- (b) $P_1 X_2 = P_1 - P_2$.

Proof. (a) If $i = j$ this is (R1). If $i < j$ then, by (R5) and induction,

$$P_i P_j = P_i (P_{j-1} T_{j-1} P_{j-1} - (q - q^{-1})P_{j-1}) = P_{j-1} T_{j-1} P_{j-1} - (q - q^{-1})P_{j-1} = P_j.$$

(b) We use relations (A1), (R4), and (R5) to get

$$\begin{aligned}
P_1X_2 &= P_1T_1(1 - P_1)T_1 = P_1T_1^2 - P_1T_1P_1T_1 \\
&= (q - q^{-1})P_1T_1 + P_1 - P_1T_1P_1T_1 \\
&= (q - q^{-1})P_1T_1 + P_1 - q^{-1}P_2T_1 - (q - q^{-1})P_1T_1 \\
&= P_1 - q^{-1}P_2T_1 = P_1 - P_2. \quad \blacksquare
\end{aligned}$$

Proposition 1.5. *The q -rook monoid algebra $R_k(q)$ is generated by the elements X_1, T_1, \dots, T_{k-1} , and these elements satisfy the relations (A1), (A2), (A3), and*

- (B1) $X_1T_j = T_jX_1$, for $2 \leq j \leq k$,
- (B2) $X_1^2 = X_1$,
- (B3) $X_1T_1X_1T_1 = T_1X_1T_1X_1$,
- (B4) $(1 - X_1)(T_1 - q)(1 - X_1)(1 - X_2) = 0$, where $X_2 = T_1X_1T_1$.

Proof. By (R5), $R_n(q)$ is generated by $X_1 = 1 - P_1, T_1, \dots, T_{k-1}$.

(B1) By (R3), $X_1T_j = (1 - P_1)T_j = T_j(1 - P_1) = T_jX_1$.

(B2) By (R1), $X_1^2 = (1 - P_1)^2 = 1 - 2P_1 + P_1^2 = 1 - P_1 = X_1$.

(B3) Using (R4) and (R5),

$$q(T_1P_1T_1P_1 - (q - q^{-1})T_1P_1) = T_1P_2 = P_2T_1 = q(P_1T_1P_1T_1 - (q - q^{-1})P_1T_1),$$

and so

$$P_1T_1P_1T_1 = T_1P_1T_1P_1 + (q - q^{-1})(P_1T_1 - T_1P_1). \quad (*)$$

Now, using (*) and (A1),

$$\begin{aligned}
X_1T_1X_1T_1 &= (1 - P_1)T_1(1 - P_1)T_1 \\
&= T_1^2 - P_1T_1^2 - T_1P_1T_1 + P_1T_1P_1T_1 \\
&= T_1^2 - (q - q^{-1})P_1T_1 - P_1 - T_1P_1T_1 + T_1P_1T_1P_1 + (q - q^{-1})(P_1T_1 - T_1P_1) \\
&= T_1^2 - P_1 - T_1P_1T_1 + T_1P_1T_1P_1 - (q - q^{-1})T_1P_1 \\
&= T_1^2 - T_1^2P_1 - T_1P_1T_1 + T_1P_1T_1P_1 \\
&= T_1(1 - P_1)T_1(1 - P_1) \\
&= T_1X_1T_1X_1.
\end{aligned}$$

Finally, to show (B4), we use Lemma 1.4(b),

$$\begin{aligned}
(1 - X_1)(T_1 - q)(1 - X_1)(1 - X_2) &= P_1(T_1 - q)P_1(1 - X_2) \\
&= P_1T_1P_1 - qP_1 - P_1T_1P_1X_2 + qP_1X_2 \\
&= P_1T_1P_1 - qP_1 - P_1T_1(P_1 - P_2) + q(P_1 - P_2) \\
&= -qP_2 + P_1T_1P_2 \\
&= -qP_2 + qP_1P_2 \quad \text{by (R4)} \\
&= -qP_2 + qP_2 \quad \text{by Lemma 1.4(a)} \\
&= 0. \quad \blacksquare
\end{aligned}$$

Define a new algebra $A_k(q)$ by generators

$$X_1 \quad \text{and} \quad T_1, T_2, \dots, T_{k-1}$$

and relations

$$\begin{aligned}
(\text{A1}) \quad & T_i^2 = (q - q^{-1})T_i + 1, & 1 \leq i \leq k-1, \\
(\text{A2}) \quad & T_i T_{i+1} T_i = T_{i+1} T_i T_{i+1}, & 1 \leq i \leq k-2, \\
(\text{A3}) \quad & T_i T_j = T_j T_i, & |i-j| > 1, \\
(\text{B1}) \quad & X_1 T_j = T_j X_1, & 2 \leq j \leq k, \\
(\text{B2}) \quad & X_1^2 = X_1, \\
(\text{B3}) \quad & X_1 T_1 X_1 T_1 = T_1 X_1 T_1 X_1, \\
(\text{B4}) \quad & (1 - X_1)(T_1 - q)(1 - X_1)(1 - X_2) = 0, \quad \text{where } X_2 = T_1 X_1 T_1.
\end{aligned} \tag{1.6}$$

We will show that $R_k(q) \cong A_k(q)$. Define

$$P_1 = (1 - X_1) \quad \text{and} \quad P_{i+1} = q(P_i T_i P_i - (q - q^{-1})P_i), \quad 1 \leq i \leq k-1. \tag{1.7}$$

Lemma 1.8. *Relations (B1)-(B4) are equivalent, respectively, to*

$$\begin{aligned}
(\text{B1}') \quad & P_1 T_j = T_j P_1, \text{ for } 2 \leq j \leq n, \\
(\text{B2}') \quad & P_1^2 = P_1, \\
(\text{B3}') \quad & P_2 T_1 = T_1 P_2, \\
(\text{B4}') \quad & P_2^2 = P_2.
\end{aligned}$$

Proof. Subtracting T_j from each side of

$$T_j - P_1 T_j = (1 - P_1)T_j = X_1 T_j = T_j X_1 = T_j(1 - P_1) = T_j - T_j P_1,$$

shows that (B1) is equivalent to (B1'). Relations (B2) and (B2') are equivalent since

$$1 - P_1 = X_1 = X_1^2 = (1 - P_1)^2 = 1 - 2P_1 + P_1^2.$$

Since

$$\begin{aligned}
X_1 T_1 X_1 T_1 &= (1 - P_1)T_1(1 - P_1)T_1 = (1 - P_1)T_1^2 - T_1 P_1 T_1 + P_1 T_1 P_1 T_1 \\
&= (1 - P_1)((q - q^{-1})T_1 + 1) - T_1 P_1 T_1 + (q^{-1}P_2 + (q - q^{-1})P_1)T_1 \quad (\text{by (A1) and (1.7)}) \\
&= (q - q^{-1})T_1 + 1 - (q - q^{-1})P_1 T_1 - P_1 - T_1 P_1 T_1 + q^{-1}P_2 T_1 + (q - q^{-1})P_1 T_1 \\
&= (q - q^{-1})T_1 + 1 - P_1 - T_1 P_1 T_1 + q^{-1}P_2 T_1
\end{aligned}$$

is equal to

$$\begin{aligned}
T_1 X_1 T_1 X_1 &= T_1(1 - P_1)T_1(1 - P_1) = T_1^2(1 - P_1) - T_1 P_1 T_1 + T_1 P_1 T_1 P_1 \\
&= ((q - q^{-1})T_1 + 1)(1 - P_1) - T_1 P_1 T_1 + T_1(q^{-1}P_2 + (q - q^{-1})P_1) \quad (\text{by (A1) and (1.7)}) \\
&= (q - q^{-1})T_1 + 1 - (q - q^{-1})T_1 P_1 - P_1 - T_1 P_1 T_1 + q^{-1}T_1 P_2 + (q - q^{-1})T_1 P_1 \\
&= (q - q^{-1})T_1 + 1 - P_1 - T_1 P_1 T_1 + q^{-1}T_1 P_2,
\end{aligned}$$

(B3) is equivalent to (B3').

Expanding

$$\begin{aligned}
(T_1 - q)(1 - X_2) &= (T_1 - q)(1 - T_1 X_1 T_1) = (T_1 - q)(1 - T_1(1 - P_1)T_1) \\
&= (T_1 - q)(1 - (q - q^{-1})T_1 - 1 + T_1 P_1 T_1) \quad (\text{by (A1)}) \\
&= (T_1 - q)T_1(- (q - q^{-1}) + P_1 T_1) \\
&= ((q - q^{-1})T_1 + 1) - qT_1(q^{-1} - q + P_1 T_1) \quad (\text{by (A1)}) \\
&= (1 - q^{-1}T_1)(q^{-1} - q + P_1 T_1) \\
&= q^{-1} - q + P_1 T_1 - q^{-2}T_1 + T_1 - q^{-1}T_1 P_1 T_1 \\
&= -(q - q^{-1}) + q^{-1}(q - q^{-1})T_1 + P_1 T_1 - q^{-1}T_1 P_1 T_1,
\end{aligned}$$

gives

$$\begin{aligned}
(1 - X_1)(T_1 - q)(1 - X_2)(1 - X_1) &= P_1(T_1 - q)(1 - X_2)P_1 \\
&= -(q - q^{-1})P_1 + q^{-1}(q - q^{-1})P_1 T_1 P_1 + P_1 T_1 P_1 - q^{-1}P_1 T_1 P_1 T_1 P_1 \quad (\text{by (B2')}) \\
&= -(q - q^{-1})P_1 + (2 - q^{-2})P_1 T_1 P_1 - q^{-1}(P_1 T_1 P_1)^2 \quad (\text{by (B2')}) \\
&= -(q - q^{-1})P_1 + (2 - q^{-2})(q^{-1}P_2 + (q - q^{-1})P_1) - q^{-1}(q^{-1}P_2 + (q - q^{-1})P_1)^2 \quad (\text{by (1.7)}) \\
&= (q - q^{-1})(-1 + 2 - q^{-2})P_1 + q^{-1}(2 - q^{-2})P_2 \\
&\quad - q^{-1}(q^{-2}P_2^2 + 2q^{-1}(q - q^{-1})P_2 + (q - q^{-1})^2 P_1) \\
&= (q - q^{-1})^2(q^{-1} - q^{-1})P_1 + q^{-1}(q^{-2}P_2 - q^{-2}P_2^2) \\
&= q^{-3}(P_2 - P_2^2).
\end{aligned}$$

and so $(1 - X_1)(T_1 - q)(1 - X_2)(1 - X_1) = 0$ if and only if $P_2^2 = P_2$. Thus (B4) is equivalent to (B4'). ■

Proposition 1.9. *The algebra $A_k(q)$ is generated by $T_1, \dots, T_{k-1}, P_1, \dots, P_k$, and these elements satisfy the relations (A1), (A2), (A3), and*

- (E1) $P_i T_j = T_j P_i$, for $1 \leq i < j \leq k$,
- (E2) $P_i P_j = P_j P_i = P_i$, for all $1 \leq j < i \leq k$,
- (E3) $P_i^2 = P_i$, for $1 \leq i \leq k$,
- (E4) $P_i T_j = T_j P_i = q P_i$, for $1 \leq j < i \leq k$,
- (E5) $P_{i+1} = q P_i T_i^{-1} P_i = q(P_i T_i P_i - (q - q^{-1})P_i)$, for $1 \leq i \leq k - 1$.

Proof. Since $X_1 = 1 - P_1$, the elements T_1, \dots, T_{n-1}, P_1 generate $A_k(q)$. Relation (E5) is the definition of P_{i+1} .

We prove (E1) by induction on i . The case $i = 1$ is (B1'). Assume that $j > i + 1 > 1$, then T_j commutes with P_i by induction and T_j commutes with T_i by (A3), so

$$T_j P_{i+1} = q^{-1} T_j P_i T_j P_i - (q - q^{-1}) T_j P_i = q^{-1} P_i T_j P_i T_j - (q - q^{-1}) P_i T_j = P_{i+1} T_j,$$

proving (E1).

We now prove (E2)-(E4) collectively by induction on i . The case $i = 1$ for (E2) follows from (B2') since

$$P_2 P_1 = q(P_1 T_1 P_1 - (q - q^{-1})P_1)P_1 = q(P_1 T_1 P_1 - (q - q^{-1})P_1) = P_2. \quad (*)$$

The relation $P_1P_2 = P_2$ is similar. The first two cases of (E3) are (B2') and (B4'). The $i = 1$ case of (E4) follows from (B4') since

$$\begin{aligned} P_2^2 &= P_2q(P_1T_1P_1 - (q - q^{-1})P_1) \\ &= q(P_2T_1P_1 - (q - q^{-1})P_2) \quad (\text{by } (*)) \\ &= q(T_1P_2P_1 - (q - q^{-1})P_2) \quad (\text{by (B3')}) \\ &= q(T_1P_2 - (q - q^{-1})P_2) \quad (\text{by } (*)). \end{aligned}$$

Since $P_2^2 = P_2$, we have $T_1P_2 = qP_2$. The case $P_2T_1 = qP_2$ is similar.

Now fix $i > 1$ and assume the following relations,

$$(E2^*) \quad P_iP_j = P_jP_i = P_i, \text{ for all } 1 \leq j < i,$$

$$(E3^*) \quad P_i^2 = P_i,$$

$$(E4^*) \quad P_iT_j = T_jP_i = qP_i, \text{ for } 1 \leq j < i,$$

We show each of these relations for $i + 1$.

For (E2) we use (E3*) to get

$$P_{i+1}P_i = q(P_iT_iP_i^2 - (q - q^{-1})P_i^2) = q(P_iT_iP_i - (q - q^{-1})P_i) = P_{i+1},$$

and when $j < i$, we use (E2*) to get

$$P_{i+1}P_j = q(P_iT_iP_iP_j - (q - q^{-1})P_iP_j) = q(P_iT_iP_i - (q - q^{-1})P_i) = P_{i+1}.$$

The relations $P_iP_{i+1} = P_{i+1}$ and $P_jP_{i+1} = P_{i+1}$ are similar, and so (E2) is established.

To establish (E3), let $i > 2$ (note that we have established $i = 1, 2$),

$$\begin{aligned} P_{i+1}^2 &= q^2(P_iT_iP_i - (q - q^{-1})P_i)^2 \\ &= q^2(P_iT_iP_iT_iP_i - 2(q - q^{-1})P_iT_iP_i + (q - q^{-1})^2P_i) \quad (\text{by (E3*)}) \\ &= q^2(P_iT_iqP_{i-1}T_{i-1}P_{i-1}T_iP_i - q(q - q^{-1})P_iT_iP_{i-1}T_iP_i \\ &\quad - 2(q - q^{-1})P_iT_iP_i + (q - q^{-1})^2P_i) \quad (\text{by (E5)}) \\ &= q^2(qP_iP_{i-1}T_iT_{i-1}T_iP_{i-1}P_i - q(q - q^{-1})P_iP_{i-1}T_i^2P_i \\ &\quad - 2(q - q^{-1})P_iT_iP_i + (q - q^{-1})^2P_i) \quad (\text{by (E1)}) \\ &= q^2(qP_iT_iT_{i-1}T_iP_i - q(q - q^{-1})P_iT_i^2P_i - 2(q - q^{-1})P_iT_iP_i + (q - q^{-1})^2P_i) \quad (\text{by (E2)}) \\ &= q^2(qP_iT_{i-1}T_iT_{i-1}P_i - q(q - q^{-1})P_iT_i^2P_i - 2(q - q^{-1})P_iT_iP_i + (q - q^{-1})^2P_i) \quad (\text{by (A2)}) \\ &= q^2(qP_iT_{i-1}T_iT_{i-1}P_i - q(q - q^{-1})^2P_iT_iP_i - q(q - q^{-1})P_i \\ &\quad - 2(q - q^{-1})P_iT_iP_i + (q - q^{-1})^2P_i) \quad (\text{by (A1)}) \\ &= q^2(q^3P_iT_iP_i - q(q - q^{-1})^2P_iT_iP_i - q(q - q^{-1})P_i \\ &\quad - 2(q - q^{-1})P_iT_iP_i + (q - q^{-1})^2P_i) \quad (\text{by (E4*)}) \\ &= q^2((q^3 - q(q - q^{-1})^2 - 2(q - q^{-1}))P_iT_iP_i + (q - q^{-1})(-q + q - q^{-1})P_i) \\ &= q(P_iT_iP_i - (q - q^{-1})P_i) \\ &= P_{i+1}. \end{aligned}$$

Finally, we prove (E4). First let $j < i$. Then, by (E4*),

$$P_{i+1}T_j = q(P_iT_iP_iT_j - (q - q^{-1})P_iT_j) = q(qP_iT_iP_i - (q - q^{-1})qP_i) = qP_{i+1},$$

and $T_j P_{i+1} = q P_{i+1}$ is similar. Now we consider the case where $j = i$,

$$\begin{aligned}
P_{i+1} T_i &= q(P_i T_i P_i T_i - (q - q^{-1}) P_i T_i) \quad (\text{by (E5)}) \\
&= q(P_i T_i q P_{i-1} T_{i-1} P_{i-1} T_i - q(q - q^{-1}) P_i T_i P_{i-1} T_i - (q - q^{-1}) P_i T_i) \quad (\text{by (E5)}) \\
&= q(q P_i P_{i-1} T_i T_{i-1} T_i P_{i-1} - q(q - q^{-1}) P_i P_{i-1} T_i^2 - (q - q^{-1}) P_i T_i) \quad (\text{by (E1)}) \\
&= q(q P_i T_i T_{i-1} T_i P_{i-1} - q(q - q^{-1}) P_i T_i^2 - (q - q^{-1}) P_i T_i) \quad (\text{by (E2)}) \\
&= q(q P_i T_{i-1} T_i T_{i-1} P_{i-1} - q(q - q^{-1}) P_i T_i^2 - (q - q^{-1}) P_i T_i) \quad (\text{by (A2)}) \\
&= q(q^2 P_i T_i T_{i-1} P_{i-1} - q(q - q^{-1}) P_i T_i^2 - (q - q^{-1}) P_i T_i) \quad (\text{by (E4*)}) \\
&= q(q^2 P_i T_i T_{i-1} P_{i-1} - q(q - q^{-1})^2 P_i T_i - q(q - q^{-1}) P_i - (q - q^{-1}) P_i T_i) \quad (\text{by (A1)}) \\
&= q(q^2 P_i T_i T_{i-1} P_{i-1} - q^2 (q - q^{-1}) P_i T_i - q(q - q^{-1}) P_i) \\
&= q(q^2 P_i P_{i-1} T_i T_{i-1} P_{i-1} - q^2 (q - q^{-1}) P_i T_i - q(q - q^{-1}) P_i) \quad (\text{by (E2)}) \\
&= q(q^2 P_i T_i P_{i-1} T_{i-1} P_{i-1} - q^2 (q - q^{-1}) P_i T_i - q(q - q^{-1}) P_i) \quad (\text{by (E1)}) \\
&= q(q P_i T_i P_i + q^2 (q - q^{-1}) P_i T_i P_{i-1} - q^2 (q - q^{-1}) P_i T_i - q(q - q^{-1}) P_i) \quad (\text{by (E5)}) \\
&= q(P_{i+1} + q^2 (q - q^{-1}) P_i T_i P_{i-1} - q^2 (q - q^{-1}) P_i T_i) \quad (\text{by (E5)}) \\
&= q(P_{i+1} + q^2 (q - q^{-1}) P_i P_{i-1} T_i - q^2 (q - q^{-1}) P_i T_i) \quad (\text{by (E1)}) \\
&= q(P_{i+1} + q^2 (q - q^{-1}) P_i T_i - q^2 (q - q^{-1}) P_i T_i) \quad (\text{by (E2)}) \\
&= q P_{i+1}.
\end{aligned}$$

The case $T_i P_{i+1} = q P_{i+1}$ is similar. ■

Propositions 1.5 and 1.9 give the following theorem.

Theorem 1.10. $R_k(q) \cong A_k(q)$ and thus (1.6) is a new presentation of $R_k(q)$.

2. Hecke algebras

The affine Hecke algebra \tilde{H}_k

Fix $q \in \mathbb{C}^*$. The affine Hecke algebra \tilde{H}_k is the algebra given by generators

$$X_1, \dots, X_k \quad \text{and} \quad T_1, \dots, T_{k-1}$$

with relations

- (1) $T_i T_j = T_j T_i$, $|i - j| > 1$,
- (2) $T_i T_{i+1} T_i = T_{i+1} T_i T_{i+1}$, $1 \leq i \leq k - 2$,
- (3) $T_i^2 = (q - q^{-1}) T_i + 1$, $1 \leq i \leq k$,
- (4) $X_i X_j = X_j X_i$, $1 \leq i, j \leq k$,
- (5) $X_i T_i = T_i X_{i+1} + (q - q^{-1}) X_i$, $1 \leq i \leq k - 1$.

It follows from relations (3) and (5) that

$$X_i = T_{i-1} \cdots T_2 T_1 X_1 T_1 T_2 \cdots T_{i-1}, \quad \text{for } 1 \leq i \leq k,$$

and from (4) that

$$(6) \quad X_1 T_1 X_1 T_1 = T_1 X_1 T_1 X_1.$$

In fact, \tilde{H}_k can be presented as the algebra generated by X_1 and T_1, \dots, T_{k-1} with relations (1-3) and (6).

Let

$$[k]! = [1][2] \cdots [k], \quad \text{where} \quad [i] = 1 + q^2 + \cdots + q^{2(i-1)}.$$

When $[k]! \neq 0$ a large class of irreducible representations of the affine Hecke algebra $\tilde{H}_k(q)$, the integrally calibrated irreducible representations, have a simple combinatorial construction. An \tilde{H}_k -module M is *integrally calibrated* if M has a basis of simultaneous eigenvectors for X_1, X_2, \dots, X_k for which the eigenvalues are all of the form q^j with $j \in \mathbb{Z}$. The construction of these \tilde{H}_k -modules is originally due to Cherednik [Ch] (see [Ra] for greater detail) and is a generalization of the classical seminormal construction of the irreducible representations of the symmetric group by A. Young. Young's construction had been generalized to Iwahori-Hecke algebras of classical type (see Theorem 2.8 below) by Hoefsmit [Ho] in 1974.

To describe the construction we shall use the notations of [Mac] for partitions so that a partition is identified with a collection of boxes in a corner, $\ell(\lambda)$ is the number of rows of λ , and $|\lambda|$ is the number of boxes in λ . For example, the partition

$$\lambda = (5, 5, 3, 1, 1) = \begin{array}{|c|c|c|c|c|} \hline \square & \square & \square & \square & \square \\ \hline \square & \square & \square & & \\ \hline \square & \square & \square & & \\ \hline \square & & & & \\ \hline \square & & & & \\ \hline \end{array} \quad \text{has } \ell(\lambda) = 5 \text{ and } |\lambda| = 15.$$

If λ is a partition that is obtained from μ by adding k boxes let λ/μ be the *skew shape* consisting of those boxes of λ that are not in μ . A *standard tableau* of shape λ/μ is a filling of the boxes of λ/μ with $1, 2, \dots, k$ such that

- (a) the entries in the rows increase left to right, and
- (b) the entries in the columns increase top to bottom.

If b is a box in λ/μ define

$$CT(b) = q^{2(c-r)}, \quad \text{if } b \text{ is in position } (r, c) \text{ of } \lambda. \tag{2.1}$$

Theorem 2.2. ([Ch], see also [Ra, Theorem 4.1], and [OR, Theorem 6.20a]) Assume that $[k]! \neq 0$. Then the calibrated irreducible representations $H^{\lambda/\mu}$ of the affine Hecke algebra \tilde{H}_k are indexed by skew shapes and can be given explicitly as the vector space

$$H^{\lambda/\mu} = \mathbb{C}\text{-span}\{v_L \mid L \text{ is a standard tableau of shape } \lambda/\mu\}$$

(so that the symbols v_L form a basis of $H^{\lambda/\mu}$) with \tilde{H}_k -action given by

$$\begin{aligned} X_i v_L &= CT(L(i)) v_L, \\ T_i v_L &= \left(\frac{CT(L(i+1))(q - q^{-1})}{CT(L(i+1)) - CT(L(i))} \right) v_L + \left(q^{-1} + \frac{CT(L(i+1))(q - q^{-1})}{CT(L(i+1)) - CT(L(i))} \right) v_{s_i L}, \end{aligned}$$

where

$s_i L$ is the same as L except i and $i + 1$ are switched, and

$v_{s_i L} = 0$, if $s_i L$ is not a standard tableau.

Remark 2.3. In [OR] it is explained how the basis v_L of $H^{\lambda/\mu}$ and the action of \tilde{H}_k in Theorem 2.2 can be derived in a natural way from the general mechanism of quantum groups (\mathcal{R} -matrices, quantum Casimirs, the tensor product rule in (3.1)) and a Schur-Weyl duality theorem (Theorem 3.3 below) for the affine Hecke algebra.

The cyclotomic Hecke algebra $H_k(u_1, \dots, u_r; q)$

Let $u_1, \dots, u_r \in \mathbb{C}$ and $q \in \mathbb{C}^*$. The cyclotomic Hecke algebra $H_k(u_1, \dots, u_r; q)$ is the quotient of the affine Hecke algebra H_k by the ideal generated by the relation

$$(X_1 - u_1)(X_1 - u_2) \cdots (X_1 - u_r) = 0. \quad (2.4)$$

The algebra $H_k(u_1, \dots, u_r; q)$ is a deformation of the group algebra of the complex reflection group $G(r, 1, k) = (\mathbb{Z}/r\mathbb{Z}) \wr S_k$ and is of dimension $\dim(H_k(u_1, \dots, u_r; q)) = r^k k!$. These algebras were introduced by Ariki and Koike [AK]. Ariki has generalized the classical result of Gyoja and Uno [GU] and given precise conditions for the semisimplicity of the cyclotomic Hecke algebras.

Theorem 2.5. ([Ar]) The algebra $H_k(u_1, \dots, u_r; q)$ is semisimple if and only if

$$q^{2d} u_i \neq u_j \text{ for all } -k < d < k, 1 \leq i < j \leq r, \quad \text{and} \quad [k]! \neq 0,$$

where $[k]! = [1][2] \cdots [k]$ and $[i] = 1 + q^2 + \cdots + q^{2(i-1)}$.

Proof. Let us only explain the conversion between the statement in [Ar] and the statement here. This conversion is the same as in Remark 1.2. If $\tilde{T}_i = qT_i$ then $\tilde{T}_i^2 = q^2((q - q^{-1})T_i + 1) = (q^2 - 1)qT_i + q^2 = (q^2 - 1)\tilde{T}_i + q^2$, which shows that our algebra is the same as Ariki's except with parameter q^2 . ■

Ariki and Koike give a combinatorial construction of the irreducible representations of the cyclotomic Hecke algebra $H_k(u_1, \dots, u_r; q)$ when it is semisimple. Define

$$\hat{H}_k^{(r)} = \{r\text{-tuples } \lambda = (\lambda^{(1)}, \dots, \lambda^{(r)}) \text{ of partitions with } k \text{ boxes total}\}. \quad (2.6)$$

Let $\lambda \in \hat{H}_k^{(r)}$. A standard tableau of shape λ is a filling of the boxes of λ with $1, 2, \dots, k$ such that for each $\lambda^{(i)}$, $1 \leq i \leq r$,

- (a) the entries in the rows are increasing left to right, and
- (b) the entries in the columns are increasing top to bottom.

Let $L(i)$ denote the the box of L containing i , and define

$$CT(b) = u_i q^{2(c-r)}, \quad \text{if the box } b \text{ is in position } (r, c) \text{ of } \lambda^{(i)}. \quad (2.7)$$

Theorem 2.8. [AK, Theorem 3.7] If $H_k(u_1, u_2, \dots, u_r; q)$ is semisimple its irreducible representations H^λ , $\lambda \in \hat{H}_k^{(r)}$, are given by

$$H^\lambda = H^{(\lambda^{(1)}, \dots, \lambda^{(r)})} = \mathbb{C}\text{-span}\{v_L \mid L \text{ is a standard tableau of shape } \lambda\}$$

(so that the symbols v_L form a basis of the vector space H^λ) with $H_k(u_1, \dots, u_r; q)$ -action given by

$$X_i v_L = CT(L(i))v_L, \quad \text{and} \quad T_i v_L = (T_i)_{LL} v_L + (q^{-1} + (T_i)_{LL})v_{s_i L},$$

where

$$(T_i)_{LL} = \begin{cases} q, & \text{if } L(i) \text{ and } L(i+1) \text{ are in the same row,} \\ & \text{of } \lambda^{(j)} \text{ for some fixed } j, \\ -q^{-1}, & \text{if } L(i) \text{ and } L(i+1) \text{ are in the same column,} \\ & \text{of } \lambda^{(j)} \text{ for some fixed } j, \\ \frac{CT(L(i+1))(q - q^{-1})}{CT(L(i+1)) - CT(L(i))}, & \text{otherwise,} \end{cases}$$

$s_i L$ is the same as L except i and $i+1$ are switched, and

$v_{s_i L} = 0$, if $s_i L$ is not a standard tableau.

It is interesting to note that Theorem 2.8 is almost an immediate consequence of Theorem 2.2.

The Iwahori-Hecke algebra $H_k(u_1, u_2; q)$ of type B_k

The Iwahori-Hecke algebra of type B_k is the cyclotomic Hecke algebra $H_k(u_1, u_2; q)$. Thus, for $u_1, u_2 \in \mathbb{C}$ and $q \in \mathbb{C}^*$, $H_k(u_1, u_2; q)$ is the quotient of the affine Hecke algebra by the ideal generated by the relation

$$(X_1 - u_1)(X_1 - u_2) = 0. \tag{2.9}$$

The algebra $H_k(1, -1; q)$ is the group algebra of the Weyl group of type B_k (the hyperoctahedral group of signed permutations).

In the case of the Iwahori-Hecke algebra $H_k(u_1, u_2; q)$ of type B_k Theorem 2.8 is due to Hoefsmit [Ho]. When $H_k(u_1, u_2; q)$ is semisimple Hoefsmit's construction of the irreducible representations of $H_k(u_1, u_2; q)$ implies that, as $H_{k-1}(u_1, u_2; q)$ -modules

$$\text{Res}_{H_{k-1}}^{H_k} H^\lambda = \bigoplus_{\lambda^-} H^{\lambda^-}, \tag{2.10}$$

where the sum runs over all pairs of partitions λ^- which are obtained from λ by removing a single box, and

$$H^{\lambda^-} = \mathbb{C}\text{-span} \left\{ v_L \mid \begin{array}{l} L \text{ is a standard tableau of shape } \lambda \\ \text{and } L^- \text{ has shape } \lambda^- \end{array} \right\}, \tag{2.11}$$

where L^- is the standard tableau with $k-1$ boxes which is obtained by removing the entry k from L . The restriction rules (2.10) can be encoded in the *Bratteli diagram* for the sequence of algebras

$$H_1(u_1, u_2; q) \subseteq H_2(u_1, u_2; q) \subseteq H_3(u_1, u_2; q) \subseteq \dots \tag{2.12}$$

i.e., the graph which has

$$\text{vertices on level } k \text{ indexed by } \lambda \in \hat{H}_k^{(2)} \quad \text{and} \quad \text{edges } \lambda \longleftrightarrow \lambda^-$$

if λ^- is obtained from λ by removing a single box. The first few rows of the Bratteli diagram for $H_k(u_1, u_2; q)$ are displayed in Figure 1.

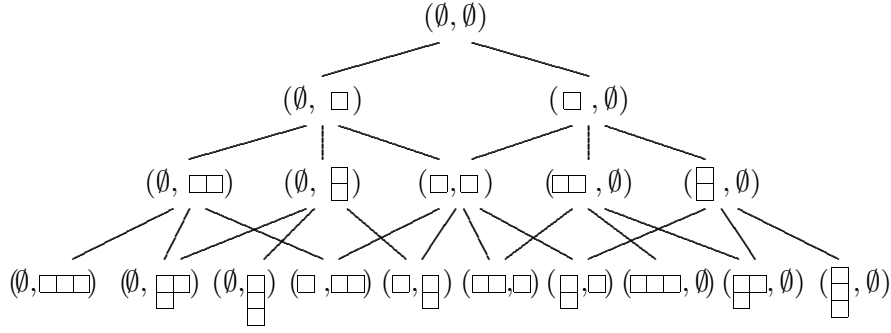
Figure 1. Bratteli Diagram for $H_k(u_1, u_2; q)$

If $H_k(u_1, u_2; q)$ is semisimple then

$$H_k(u_1, u_2; q) \cong \bigoplus_{\lambda \in \hat{B}_k} M_{d_\lambda}(\mathbb{C}), \quad (2.13)$$

where d_λ is the number of standard tableaux L of shape λ , and $M_d(\mathbb{C})$ is the algebra of $d \times d$ matrices with entries from \mathbb{C} .

The minimal ideals I^λ of $H_k(u_1, u_2; q)$ are in one-to-one correspondence with the summands in (2.13). Let $m < k$, let I^μ be a fixed minimal ideal of $H_m(u_1, u_2; q)$ and define

$$\langle I^\mu \rangle_k \text{ is the ideal of } H_k(u_1, u_2; q) \text{ generated by } I^\mu$$

($I^\mu \subseteq H_m(u_1, u_2; q) \subseteq H_k(u_1, u_2; q)$). The restriction rules (2.10) imply that

$$\langle I^\mu \rangle_k = \bigoplus_{\lambda \supseteq \mu} I^\lambda, \quad (2.14)$$

where the sum is over all pairs of partitions $\lambda = (\lambda^{(1)}, \lambda^{(2)}) \in H_k^{(2)}$ which are obtained from $\mu = (\mu^{(1)}, \mu^{(2)}) \in \hat{H}_m^{(2)}$ by adding $(k - m)$ boxes.

The ideal $I^{((1^2), \emptyset)}$

Lemma 2.15. *Assume that $H_2(u_1, u_2; q)$ is semisimple. The minimal ideal $I^{((1^2), \emptyset)}$ of $H_2(u_1, u_2; q)$ is generated by the element*

$$p = \begin{cases} (X_1 - u_2)(X_2 - u_2)(X_2 - q^2 u_1), & \text{if } u_1 \neq 0, \\ (X_1 - u_2)(T_1 - q)(X_1 - u_2)(X_2 - u_2), & \text{if } u_1 = 0, \end{cases} \quad \text{where } X_2 = T_1 X_1 T_1.$$

Proof. Using the construction of the simple $H_2(u_1, u_2; q)$ -modules in Theorem 2.8 it is not tedious to check that, when $u_1 \neq 0$,

$$pv_L = \begin{cases} (u_1 - u_2)(q^{-2}u_1 - u_2)(q^{-2}u_1 - q^2u_1)v_L, & \text{if } L \text{ has shape } ((1^2), \emptyset), \\ 0, & \text{otherwise,} \end{cases}$$

and, when $u_1 = 0$,

$$pv_L = \begin{cases} (0 - u_2)(-q^{-1} - q)(0 - u_2)(0 - u_2)v_L, & \text{if } L \text{ has shape } ((1^2), \emptyset), \\ 0, & \text{otherwise.} \end{cases}$$

Thus p is an element of the ideal $I^{((1^2), \emptyset)}$. Since $I^{((1^2), \emptyset)}$ is a minimal ideal it is generated by any one of its (nonzero) elements. ■

The algebra $A_k(u_1, u_2; q)$

Let $u_1 \in \mathbb{C}$ and $u_2, q \in \mathbb{C}^*$. Let $A_k(u_1, u_2; q)$ be the algebra given by generators

$$X_1 \quad \text{and} \quad T_1, T_2, \dots, T_{k-1}$$

and relations

- (1) $T_i T_j = T_j T_i, \quad |i - j| > 1,$
- (2) $T_i T_{i+1} T_i = T_{i+1} T_i T_{i+1}, \quad 1 \leq i \leq n - 2,$
- (3) $T_i^2 = (q - q^{-1})T_i + q, \quad 1 \leq i \leq k - 1,$
- (4) $X_1 T_1 X_1 T_1 = T_1 X_1 T_1 X_1,$
- (5) $(X_1 - u_1)(X_1 - u_2) = 0,$
- (6) $(X_1 - u_2)(X_2 - u_2)(X_2 - q^2 u_1) = 0, \quad \text{if } u_1 \neq 0,$
 $(X_1 - u_2)(T_1 - q)(X_1 - u_2)(X_2 - u_2), \quad \text{if } u_1 = 0, \quad \text{where } X_2 = T_1 X_1 T_1.$

Let

$$\hat{A}_k = \{(\lambda^{(1)}, \lambda^{(2)}) \in \hat{H}_k^{(2)} \mid \lambda^{(1)} \text{ has at most one row}\}. \quad (2.16)$$

Theorem 2.17. Assume $H_k(u_1, u_2; q)$ is semisimple.

- (a) $A_k(u_1, u_2; q)$ is semisimple.
- (b) As in (2.14) let $\langle I^{((1^2), \emptyset)} \rangle_k$ be the ideal of $H_k(u_1, u_2; q)$ generated by the minimal ideal $I^{((1^2), \emptyset)}$ of $H_2(u_1, u_2; q)$. Then

$$A_k(u_1, u_2; q) \cong \frac{H_k(u_1, u_2; q)}{\langle I^{((1^2), \emptyset)} \rangle_k}.$$

- (c) As in (2.13) let d_λ denote the number of standard tableaux of shape $\lambda = (\lambda^{(1)}, \lambda^{(2)})$ and $M_d(\mathbb{C})$ the algebra of $d \times d$ matrices with entries from \mathbb{C} . Then

$$A_k(u_1, u_2; q) \cong \bigoplus_{\lambda \in \hat{A}_k} M_{d_\lambda}(\mathbb{C}).$$

- (d) The irreducible $A_k(u_1, u_2; q)$ -modules $H^\lambda, \lambda \in \hat{A}_k$, are given by Hoefsmit's construction (Theorem 2.8).
- (e) The Bratteli diagram for the sequence of algebras $A_1(u_1, u_2; q) \subseteq A_2(u_1, u_2; q) \subseteq \dots \subseteq A_k(u_1, u_2; q)$ has vertices on level m indexed by $\lambda \in \hat{A}_m$ and edges $\lambda \longleftarrow \lambda^-$ if λ^- is obtained from λ by removing a box. See Figure 2.

Proof. (a) follows from the fact that $A_k(u_1, u_2; q)$ is a quotient of $H_k(u_1, u_2; q)$.

(b) By Lemma 2.15, the element p generates the ideal $\langle I^{((1^2), \emptyset)} \rangle$ in $H_k(u_1, u_2; q)$ and so this is a consequence of the definition of $A_k(u_1, u_2; q)$.

(c) By (2.14)

$$\langle I^{((1^2), \emptyset)} \rangle_k = \bigoplus_{\lambda \supseteq ((1^2), \emptyset)} I^\lambda, \quad (2.18)$$

and so, by (b) and (2.13), the simple components of $A_k(u_1, u_2; q)$ are indexed by those elements of $\lambda \in \hat{H}_k^{(2)}$ which do not contain $((1^2), \emptyset)$. These are exactly the elements of \hat{A}_k .

(d) and (e) are consequences of (b), (c) and (2.18). ■

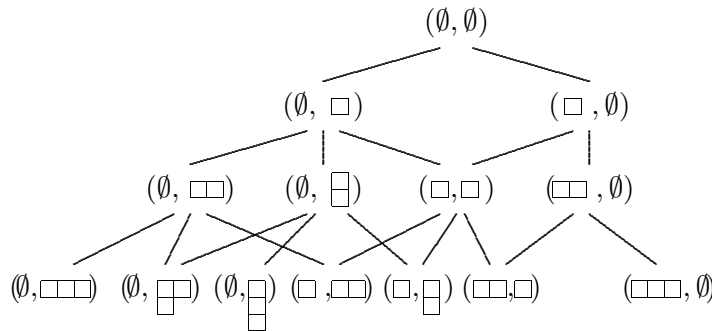

Figure 2. Bratteli Diagram of $A_k(u_1, u_2; q)$ and $R_k(q)$

By construction it is clear that the Bratteli diagram for $A_k(u_1, u_2; q)$ is a subgraph of the Bratteli diagram for $H_k(u_1, u_2; q)$. It is the subgraph which is obtained by removing all pairs of partitions $\lambda = (\lambda^{(1)}, \lambda^{(2)})$ which appear in (2.18) (for all k). Thus, it is the subgraph which is obtained by removing the vertex $((1^2), \emptyset)$ and all its *descendants*, i.e., all pairs of partitions $\lambda = (\lambda^{(1)}, \lambda^{(2)})$ which are obtained by adding boxes to $((1^2), \emptyset)$.

Theorem 2.19. *The algebra $A_k(u_1, u_2; q)$ is semisimple if and only if*

$$q^{2d}u_1 \neq u_2 \text{ for all } -k < d < k, \quad \text{and} \quad [k]! \neq 0,$$

where $[k]! = [1][2] \cdots [k]$ and $[i] = 1 + q^2 + \cdots + q^{2(i-1)}$.

Proof. Since $A_k(u_1, u_2; q)$ is a quotient of $H_k(u_1, u_2; q)$, we know that $A_k(u_1, u_2; q)$ is semisimple when $H_k(u_1, u_2; q)$ is. Thus $A_k(u_1, u_2; q)$ is semisimple when (a) and (b) hold.

The Iwahori-Hecke algebra $H_k(q)$ of type A_{k-1} is the cyclotomic Hecke algebra $H_k(1, 1; q)$. Thus, $H_k(q)$ is the quotient $A_k(u_1, u_2; q)$ by the relation $X_1 = u_1$. By Theorem 2.5 (in this case originally due to Gyoja and Uno) $H_k(q)$ is semisimple if and only if $[k]! \neq 0$. Since $H_k(q)$ is a quotient of $A_k(u_1, u_2; q)$, the algebra $A_k(u_1, u_2; q)$ is not semisimple when $H_k(q)$ is not semisimple. Thus, $A_k(u_1, u_2; q)$ is not semisimple when $[k]! = 0$.

If $u_1 = u_2$ then the representation $\rho: A_k(u_1, u_2; q) \rightarrow M_2(\mathbb{C})$ given by setting

$$\rho(X_1) = \begin{pmatrix} u_1 & 1 \\ 0 & u_1 \end{pmatrix} \quad \text{and} \quad \rho(T_i) = \begin{pmatrix} q & 0 \\ 0 & q \end{pmatrix}$$

is an indecomposable representation which is not irreducible. Thus $A_k(u_1, u_1; q)$ is not semisimple.

The Tits deformation theorem (see [CR, (68.17)]) says that the algebra $A_k(u_1, u_2; q)$ has the same structure for any choice of the parameters u_1, u_2 for which it is semisimple. Assume that $[k]! \neq 0$ and $u_2 = q^{2d}u_1$, $u_1 \neq 0$. Let λ/μ be the skew shape given by $\lambda = (k-1, d)$ and $\mu = (d-1)$ and define

$$CT(b) = u_1 q^{2(c-r)+2}, \quad \text{if } b \text{ is a box in position } (r, c) \text{ of } \lambda.$$

With these definitions the formulas in Theorem 2.2 define an $H_k(u_1, q^{2d}u_1; q)$ -module $H^{\lambda/\mu}$. A check that

$$(X_1 - q^{2d}u_1)(X_2 - q^{2d}u_1)(X_2 - q^2u_1)v_L = 0,$$

for all standard tableaux L of shape λ/μ shows that that $H^{\lambda/\mu}$ is an $A_k(u_1, q^{2d}u_1; q)$ -module. The standard proof (see [Ra, Theorem 4.1]) of Theorem 2.5 applies in this case to show that $H^{\lambda/\mu}$ is an irreducible $A_k(u_1, q^{2d}u_1; q)$ -module. It has dimension

$$\dim(H^{\lambda/\mu}) = (\text{the number of standard tableaux of shape } \lambda/\mu) = \binom{k}{d} - 1.$$

When we restrict this $A_k(u_1, q^{2d}u_1; q)$ -module to $H_k(q)$, it is a direct sum of irreducible $H_k(q)$ -modules indexed by partitions $\nu \vdash k$ with multiplicity given by the classical Littlewood-Richardson coefficient $c_{\mu\nu}^\lambda$ (see [Ra, Theorem 6.1]). Since $\lambda = (k-1, d)$ and $\mu = (d-1)$ we have $c_{\mu\nu}^\lambda \neq 0$ only if ν has ≤ 2 rows and $c_{\mu\nu}^\lambda = 0$ when $\nu = (k)$. So $H^{\lambda/\mu}$ is an irreducible $A_k(u_1, q^{2d}u_1; q)$ -module such that upon restriction to $H_k(q)$ is a direct sum of irreducible representations indexed by partitions with length ≤ 2 , and which does not contain the “trivial” representation of $H_k(q)$.

When $A_k(u_1, u_2; q)$ is semisimple its irreducible representations H^λ are indexed by pairs of partitions $\lambda = (\lambda^{(1)}, \lambda^{(2)})$ such that $\lambda^{(1)}$ has at most one row. If $\lambda^{(1)}$ has length r , then, on restriction to $H_k(q)$, H^λ is a direct sum of irreducibles indexed by partitions $\nu \vdash k$ with multiplicities $c_{\lambda^{(1)}\lambda^{(2)}}^\nu$. By the Pieri rule [Mac, (5.16)] the resulting ν are those obtained by adding a horizontal strip of length r to $\lambda^{(2)}$. Only when $\lambda^{(2)}$ has a single row will all the ν have ≤ 2 rows and, in this case, $c_{\lambda^{(1)}\lambda^{(2)}}^\nu = c_{(r), (k-r)}^\nu = 1$ for $\nu = (k)$. Thus, when $A_k(u_1, u_2; q)$ is semisimple every irreducible representation which, on restriction to $H_k(q)$, decomposes as a direct sum of components indexed by partitions with ≤ 2 rows does contain the “trivial” representation of $H_k(q)$.

Thus, the Tits deformation theorem implies that $A_k(u_1, q^{2d}u_1; q)$ is not semisimple. ■

Remark 2.20. It is interesting to note that the blob algebras (see [MW]) are also quotients of $A_k(u_1, u_2; q)$.

The q -rook monoid algebras $R_k(q)$

The new presentation of the q -rook monoid given in Section 1 shows that

$$R_k(q) = A_k(0, 1; q),$$

and thus $R_k(q)$ is a quotient of Iwahori-Hecke algebra $H_n(0, 1; q)$ of type B_k .

Corollary 2.21.

- (a) *The q -rook monoid algebra $R_k(q)$ is semisimple if and only if $[k]_q! \neq 0$.*
- (b) *If $R_k(q)$ is semisimple then the irreducible representations of $R_k(q)$ are indexed by $\lambda \in \hat{A}_k$ (see (2.16)) and are given explicitly by the construction in Theorem 2.8.*

Part (a) of Corollary 2.21 is Theorem 2.19 applied to $R_k(q)$ and (b) is Theorem 2.17(e) for $R_k(q)$. Part (a) was proved in a different way by Solomon [So4] and part (b) is the result of Halverson [Ha, Theorem 3.2] which was the catalyst for the results of this paper.

As in (2.10) it follows that, as $R_{k-1}(q)$ -modules

$$\text{Res}_{R_{k-1}}^{R_k} R^\lambda = \bigoplus_{\lambda^-} R^{\lambda^-},$$

where the sum runs over all pairs of partitions λ^- which are obtained from λ by removing a single box, and

$$R^{\lambda^-} = \mathbb{C}\text{-span}\{v_L \mid L^- \text{ has shape } \lambda^-\},$$

where L^- is the standard tableau with $k-1$ boxes which is obtained by removing the k from L . The first few rows of the Bratteli diagram for the sequence of algebras

$$R_1(q) \subseteq R_2(q) \subseteq R_3(q) \subseteq \cdots$$

are as displayed in Figure 2.

3. Schur-Weyl dualities

Let $U_q\mathfrak{gl}(n)$ be the quantum group corresponding to $GL_n(\mathbb{C})$. This is the algebra given by generators

$$e_i, \quad f_i, \quad (1 \leq i < n), \quad \text{and} \quad q^{\pm\varepsilon_i}, \quad (1 \leq i \leq n),$$

with relations

$$\begin{aligned} q^{\varepsilon_i} q^{\varepsilon_j} &= q^{\varepsilon_j} q^{\varepsilon_i}, & q^{\varepsilon_i} q^{-\varepsilon_i} &= q^{-\varepsilon_i} q^{\varepsilon_i} = 1, \\ q^{\varepsilon_i} e_j q^{-\varepsilon_i} &= \begin{cases} q^{-1} e_j, & \text{if } j = i-1, \\ q e_j, & \text{if } j = i, \\ e_j, & \text{otherwise,} \end{cases} & q^{\varepsilon_i} f_j q^{-\varepsilon_i} &= \begin{cases} q f_j, & \text{if } j = i-1, \\ q^{-1} f_j, & \text{if } j = i, \\ f_j, & \text{otherwise,} \end{cases} \\ e_i f_j - f_j e_i &= \delta_{ij} \frac{q^{\varepsilon_i - \varepsilon_{i+1}} - q^{-(\varepsilon_i - \varepsilon_{i+1})}}{q - q^{-1}}, \end{aligned}$$

$$e_{i\pm 1} e_i^2 - (q + q^{-1}) e_i e_{i\pm 1} e_i + e_i^2 e_{i\pm 1} = 0, \quad f_{i\pm 1} f_i^2 - (q + q^{-1}) f_i f_{i\pm 1} f_i + f_i^2 f_{i\pm 1} = 0,$$

$$e_i e_j = e_j e_i, \quad f_i f_j = f_j f_i, \quad \text{if } |i - j| > 1.$$

Part of the data of a quantum group is an \mathcal{R} -matrix, which provides a canonical $U_q\mathfrak{gl}(n)$ -module isomorphism

$$\check{R}_{MN}: M \otimes N \longrightarrow N \otimes M$$

for any two $U_q\mathfrak{gl}(n)$ -modules M and N .

The irreducible polynomial representations $L(\lambda)$ of $U_q\mathfrak{gl}(n)$ are indexed by dominant integral weights $\lambda \in L^+$ where

$$L = \sum_{i=1}^n \mathbb{Z}\varepsilon_i = \{\lambda = \lambda_1\varepsilon_1 + \cdots + \lambda_n\varepsilon_n \mid \lambda_i \in \mathbb{Z}\},$$

and $L^+ = \{\lambda \in L \mid \lambda_1 \geq \lambda_2 \geq \cdots \geq \lambda_n\}$. The elements of L^+ can be identified with partitions λ with $\leq n$ rows.

The irreducible representation

$$V = L(\varepsilon_1) \quad \text{has} \quad \dim(V) = n, \quad \text{and} \quad L(\mu) \otimes V \cong \bigoplus_{\mu^+} L(\mu^+) \quad (3.1)$$

as $U_q\mathfrak{gl}(n)$ -modules, where the direct sum is over all partitions μ^+ which are obtained from μ by adding a box. The $U_q\mathfrak{gl}(n)$ -module V can be given explicitly as the vector space

$$V = \mathbb{C}\text{-span}\{v_1, \dots, v_n\}$$

(so that the symbols v_i form a basis of V) with $U_q\mathfrak{gl}(n)$ -action given by

$$e_i v_j = \begin{cases} v_{j-1}, & \text{if } j = i + 1, \\ 0, & \text{if } j \neq i + 1, \end{cases} \quad f_i v_j = \begin{cases} v_{j+1}, & \text{if } j = i, \\ 0, & \text{if } j \neq i, \end{cases} \quad \text{and}$$

$$q^{\pm \varepsilon_i} v_j = \begin{cases} q^{\pm 1} v_j, & \text{if } j = i, \\ v_j, & \text{if } j \neq i. \end{cases}$$

With this notation the R -matrix for $V \otimes V$ is given explicitly by

$$\check{R}_{VV}: V \otimes V \rightarrow V \otimes V, \quad \text{where}$$

$$\check{R}_{VV}(v_i \otimes v_j) = \begin{cases} qv_j \otimes v_i, & \text{if } i = j, \\ v_j \otimes v_i, & \text{if } i > j, \\ v_j \otimes v_i + (q - q^{-1})(v_i \otimes v_j), & \text{if } i < j. \end{cases} \quad (3.2)$$

A Schur-Weyl duality for affine and cyclotomic Hecke algebras

Theorem 3.3. (see [OR, Theorem 6.17ab and Theorem 6.18])

(a) For any $\mu \in L^+$ there is an action of the affine Hecke algebra \tilde{H}_k on $L(\mu) \otimes V^{\otimes k}$ given by $\Phi: \tilde{H}_k \rightarrow \text{End}(L(\mu) \otimes V^{\otimes k})$ where

$$\Phi(X_1) = \check{R}_{V, L(\mu)} \check{R}_{L(\mu), V} \otimes \text{id}_V^{\otimes(k-1)} \quad \text{and} \quad \Phi(T_i) = \text{id}_{L(\mu)} \otimes \text{id}_V^{\otimes(i-1)} \otimes \check{R}_{VV} \otimes \text{id}_V^{\otimes(k-i-1)}.$$

(b) The \tilde{H}_k action on $L(\mu) \otimes V^{\otimes k}$ commutes with the $U_q\mathfrak{gl}(n)$ -action and the map

$$\Phi: \tilde{H}_k \rightarrow \text{End}_{U_q\mathfrak{gl}(n)}(L(\mu) \otimes V^{\otimes k}) \quad \text{is surjective.}$$

(c) As a $(U_q\mathfrak{gl}(n), \tilde{H}_k)$ bimodule

$$L(\mu) \otimes V^{\otimes k} \cong \bigoplus_{\lambda} L(\lambda) \otimes H^{\lambda/\mu},$$

where the sum is over all partitions λ which are obtained from μ by adding k boxes and $H^{\lambda/\mu}$ is a simple \tilde{H}_k -module.

(d) The representation Φ given in part (a) is a representation of the cyclotomic Hecke algebra $H_k(u_1, \dots, u_r; q)$, i.e.

$$\Phi: H_k(u_1, \dots, u_r; q) \rightarrow \text{End}_{U_q\mathfrak{gl}(n)}(L(\mu) \otimes V^{\otimes k}),$$

for any (multi)set of parameters u_1, \dots, u_r containing the (multi)set of values $CT(b)$ (defined in (2.1)) as b runs over the boxes which can be added to μ (to get a partition).

Remark 3.4. The affine Hecke algebra module $H^{\lambda/\mu}$ which appears in Theorem 3.3(c) is the same as the module $H^{\lambda/\mu}$ constructed in Theorem 2.2.

A Schur-Weyl duality for Iwahori-Hecke algebras of type B

Suppose that μ is a partition with two addable boxes, i.e.

$$\mu = \underbrace{d}_{\ell} \left\{ \begin{array}{|c|} \hline \square \\ \hline \end{array} \right\} = \ell^d, \quad \text{for some } 0 < d \leq n, \ell \in \mathbb{Z}_{\geq 0}.$$

Proposition 3.5. *Let $\mu = \ell^d$, $0 < d \leq n$, $\ell \in \mathbb{Z}_{\geq 0}$. Then Theorem 3.3(d) provides a Schur-Weyl duality for $H_k(u_1, u_2; q)$ with $u_1 = q^{2\ell}$ and $u_2 = q^{2d}$.*

Proof. One only needs to note that if b_1, b_2 are the addable boxes of μ and $CT(b)$ is as defined in (2.1) then

$$u_1 = CT(b_1) = q^{2\ell}, \quad \text{and} \quad u_2 = CT(b_2) = q^{2d}. \quad \blacksquare$$

A Schur-Weyl duality for $A_n(u_1, u_2; q)$

Keeping the notation of Proposition 3.5, consider the special case $\ell = n - 1$ and $d \geq k$, so that

$$\mu = \underbrace{n-1}_{\ell} \left\{ \begin{array}{|c|} \hline \square \\ \hline \end{array} \right\} = \ell^{(n-1)}, \quad \text{for some } \ell \in \mathbb{Z}_{\geq 0}.$$

Then, as a $(U_q \mathfrak{gl}(n), H_k(u_1, u_2; q))$ bimodule

$$L(\mu) \otimes V^{\otimes k} \cong \bigoplus_{\lambda} L(\lambda) \otimes H^{\lambda}, \quad \text{where} \quad \lambda = \begin{array}{|c|c|} \hline \mu & \lambda^{(2)} \\ \hline \lambda^{(1)} & \\ \hline \end{array} \quad (3.6)$$

and H^{λ} is a simple $H_k(u_1, u_2; q)$ module indexed by a pair of partitions $\lambda = (\lambda^{(1)}, \lambda^{(2)})$ with k boxes total and such that $\lambda^{(1)}$ has at most one row. The following result shows that, in this case, the Schur-Weyl duality in Theorem 3.3 becomes a Schur-Weyl duality for the algebra

$$A_k(u_1, u_2; q), \quad \text{where} \quad u_1 = q^{2(n-1)} \quad \text{and} \quad u_2 = q^{2\ell}.$$

Proposition 3.7. *Let $\mu = (n-1)^d$. Then the \tilde{H}_k action on $L(\mu) \otimes V^{\otimes k}$ which is given by Theorem 3.3 factors through the algebra $A_k(u_1, u_2; q)$, where $u_1 = q^{2(n-1)}$ and $u_2 = q^{2\ell}$.*

Proof. By Theorem 3.3(d), the \tilde{H}_k action on $L(\mu) \otimes V^{\otimes k}$ factors through the algebra $H_k(u_1, u_2; q)$ where $u_1 = q^{2(n-1)}$ and $u_2 = q^{2\ell}$. It remains to check that $(X_1 - u_2)(X_2 - u_2)X_2 - q^2 u_1 = 0$ as operators on $L(\mu) \otimes V^{\otimes k}$. To do this it is sufficient to show that $(X_1 - u_2)(X_2 - u_2)X_2 - q^2 u_1 = 0$ as operators on H^{λ} for each H^{λ} which appears in the decomposition (3.6). The $H_k(u_1, u_2; q)$ -module H^{λ} has basis indexed by the standard tableaux L of shape λ and

$$(X_1 - u_2)(X_2 - u_2)(X_2 - q^2 u_1)v_L = (CT(L(1)) - u_2)(CT(L(2)) - u_2)(CT(L(2)) - q^2 u_1)v_L.$$

For each of the possible positions of the first two boxes of L at least one of the factors in the last product is 0. Thus $(X_1 - u_2)(X_2 - u_2)X_2 - q^2 u_1 = 0$ as operators on H^{λ} . \blacksquare

Another Schur-Weyl duality for cyclotomic Hecke algebras

Let m_1, \dots, m_r be positive integers such that $m_1 + \dots + m_r = n$. Then $\mathfrak{g}_P = \mathfrak{gl}(m_1) \oplus \dots \oplus \mathfrak{gl}(m_r)$ is a Lie subalgebra of $\mathfrak{gl}(n)$, and correspondingly

$$U_P = U_q \mathfrak{gl}(m_1) \otimes \dots \otimes U_q \mathfrak{gl}(m_r) \quad \text{is a subalgebra of } U_q \mathfrak{gl}(n).$$

There is a corresponding decomposition of the fundamental representation V of $U_q \mathfrak{gl}(n)$ as a U_P -module:

$$V = V_1 \oplus \dots \oplus V_r, \quad \text{where} \quad \dim(V_j) = m_j,$$

and V_j is the fundamental representation for $U_q \mathfrak{gl}(m_j)$.

$$\text{If } v \in V_j, \quad \text{we write} \quad \deg(v) = j$$

and say that v is *homogeneous of degree* j .

Let $u_1, \dots, u_r \in \mathbb{C}$ and define

$$d: V \rightarrow V \quad \text{by} \quad d(v) = u_j v, \quad \text{if } \deg(v) = j. \quad (3.8)$$

Recall the action of $\check{R}_{VV}: V \otimes V \rightarrow V \otimes V$ as given in (3.2), define

$$\check{S}_{VV}: V \otimes V \rightarrow V \otimes V \quad \text{by} \quad \check{S}_{VV}(v \otimes w) = \begin{cases} \check{R}_{VV}(v \otimes w), & \text{if } \deg(v) = \deg(w), \\ w \otimes v, & \text{if } \deg(v) \neq \deg(w), \end{cases}$$

(for homogeneous $v, w \in V$), and define $d_i, R_i, S_i \in \text{End}(V^{\otimes k})$ by

$$\begin{aligned} d_i &= \text{id}_V^{\otimes(i-1)} \otimes d \otimes \text{id}_V^{(k-i)}, & 1 \leq i \leq k, \\ \check{R}_i &= \text{id}_V^{\otimes(i-1)} \otimes \check{R}_{VV} \otimes \text{id}_V^{(k-i-1)}, & 1 \leq i \leq k-1, \\ \check{S}_i &= \text{id}_V^{\otimes(i-1)} \otimes \check{S}_{VV} \otimes \text{id}_V^{(k-i-1)}, & 1 \leq i \leq k-1. \end{aligned} \quad (3.9)$$

Theorem 3.10. (Sakamoto-Shoji [SS])

(a) There is an action of $H_k(u_1, u_2, \dots, u_r; q)$ on $V^{\otimes k}$ given by $\Phi_P: H_k(u_1, \dots, u_r; q) \rightarrow \text{End}(V^{\otimes k})$ where

$$\Phi_P(T_i) = \check{R}_i \quad \text{and} \quad \Phi_P(X_1) = \check{R}_1^{-1} \dots \check{R}_k^{-1} \check{S}_k \dots \check{S}_1 d_1.$$

(b) The action of $H_k(u_1, \dots, u_r; q)$ commutes with the action of U_P on $V^{\otimes k}$,

$$\text{i.e., } \Phi_P: H_k(u_1, \dots, u_k; q) \rightarrow \text{End}_{U_P}(V^{\otimes k}).$$

(c) As a $(U_P, H_k(u_1, \dots, u_r; q))$ -bimodule

$$V^{\otimes k} \cong \bigoplus_{\lambda=(\lambda^{(1)}, \dots, \lambda^{(r)})} L_P(\lambda) \otimes H^\lambda,$$

where the sum is over all r -tuples $\lambda = (\lambda^{(1)}, \dots, \lambda^{(r)})$ of partitions such that $\ell(\lambda^{(j)}) \leq m_j$, $L_P(\lambda)$ is the simple U_P -module given by

$$L_P(\lambda) = L^{(1)}(\lambda^{(1)}) \otimes \dots \otimes L^{(r)}(\lambda^{(r)}),$$

where $L^{(j)}(\lambda^{(j)})$ is the simple $U_q(\mathfrak{gl}(m_j))$ -module corresponding to the partition $\lambda^{(j)}$, and H^λ is a (not necessarily simple) $H_k(u_1, \dots, u_r; q)$ -module.

Remark 3.11. The $H_k(u_1, \dots, u_k; q)$ -module H^λ appearing in Theorem 3.10(c) is simple whenever $H_k(u_1, \dots, u_k; q)$ is semisimple. In that case H^λ coincides with the $H_k(u_1, \dots, u_r; q)$ -module constructed in Theorem 2.8.

A Schur-Weyl duality for $R_k(q)$

Consider the case of Theorem 3.10 when

$$r = 2, \quad m_1 = 1, \quad m_2 = n, \quad u_1 = 0, \quad u_2 = 1.$$

Then

$$V = V_1 \oplus V_2 \quad \text{where} \quad V_1 = \mathbb{C}v_0, \quad \text{and} \quad V_2 = \mathbb{C}\text{-span}\{v_1, \dots, v_n\}.$$

Let us analyze the action of $H_k(0, 1; q)$ on $V^{\otimes k}$ as given by Sakamoto and Shoji. Since $dv_0 = u_1v_0 = 0$,

$$\Phi_P(X_1)(v_0 \otimes v_{i_2} \otimes \cdots \otimes v_{i_k}) = 0,$$

and, for $\ell > 0$,

$$\begin{aligned} \Phi_P(X_1)(v_\ell \otimes v_{i_2} \cdots \otimes v_{i_k}) &= \check{R}_1^{-1} \cdots \check{R}_{k-1}^{-1} \check{S}_{k-1} \cdots \check{S}_1 d_1(v_\ell \otimes v_{i_2} \otimes \cdots \otimes v_{i_k}) \\ &= \check{R}_1^{-1} \cdots \check{R}_{k-1}^{-1} \check{S}_{k-1} \cdots \check{S}_1(v_\ell \otimes v_{i_2} \otimes \cdots \otimes v_{i_k}) \\ &= \check{R}_1^{-1} \cdots \check{R}_{k-1}^{-1} \check{R}_{k-1} \cdots \check{R}_1(v_\ell \otimes v_{i_2} \otimes \cdots \otimes v_{i_k}) \\ &= v_\ell \otimes v_{i_2} \otimes \cdots \otimes v_{i_k}, \end{aligned}$$

and thus $\Phi_P(X_1) = d_1$. This calculation shows that the Sakamoto-Shoji action of $H_k(0, 1; q)$ coincides exactly with action for the Schur-Weyl duality for the q -rook monoid algebra $R_k(q)$ in the form given by Halverson [Ha, Corollary 6.3].

4. References

- [AK] S. ARIKI AND K. KOIKE, *A Hecke algebra of $(\mathbb{Z}/r\mathbb{Z}) \wr S_n$ and construction of its irreducible representations*, Adv. Math. **106** (1994), 216–243.
- [Ar] S. ARIKI, *On the semisimplicity of the Hecke algebra of $(\mathbb{Z}/r\mathbb{Z}) \wr S_n$* , J. Algebra **169** (1994), 216–225.
- [Ch] I. CHEREDNIK, *A new interpretation of Gelfand-Tsetlin bases*, Duke Math. J. **54** (1987), 563–577.
- [CR] C. CURTIS AND I. REINER, *Methods of Representation Theory: With Applications to Finite Groups and Orders, Volume II*, Wiley, New York, 1987.
- [GU] A. GYOJA AND K. UNO, *On the semisimplicity of Hecke algebras*, J. Math. Soc. Japan **41** (1989), 75–79.
- [Ha] T. HALVERSON, *Representations of the q -rook monoid*, preprint (2001).
- [Ho] P. N. HOEFSMIT, *Representations of Hecke algebras of finite groups with BN-pairs of classical type*, Thesis, Univ. of British Columbia, 1974.
- [Mac] I. G. MACDONALD, *Symmetric Functions and Hall polynomials*, Second edition, Oxford University Press, New York, 1995.
- [MW] P. P. MARTIN AND D. WOODCOCK, *On the structure of the blob algebra*, J. Algebra **225** (2000), 957–988.
- [Mu1] W. D. MUNN, *Matrix representations of semigroups*, Proc. Camb. Phil. Soc., **53** (1957), 5–12.

- [Mu2] W. D. MUNN, *The characters of the symmetric inverse semigroup*, Proc. Camb. Phil. Soc., **53** (1957), 13-18.
- [OR] R. ORELLANA AND A. RAM, *Affine braids, Markov traces and the category \mathcal{O}* , preprint (2001).
- [Ra] A. RAM, *Skew shape representations are irreducible*, preprint (1998).
- [So1] L. SOLOMON, *The Bruhat decomposition, Tits system and Iwahori ring for the monoid of matrices over a finite field*, Geom. Dedicata **36** (1990), 15–49.
- [So2] L. SOLOMON, *Representations of the rook monoid*, J. Algebra, to appear.
- [So3] L. SOLOMON, Abstract No. 900-16-169, Abstracts Presented to the American Math. Soc., Vol. 16, No. 2, Spring 1995.
- [So4] L. SOLOMON, *The Iwahori algebra of $\mathbf{M}_n(\mathbf{F}_q)$, a presentation and a representation on tensor space*, preprint (2001).
- [SS] S. SAKAMOTO AND T. SHOJI, *Schur-Weyl reciprocity for Ariki-Koike algebras*, J. Algebra **221** (1999), 293-314.
- [Yg] A. YOUNG, *On quantitative substitutional analysis VI*, Proc. London Math. Soc. **31** (1931), 253-289.